

718-52 Mifare Secure OEM Reader

Data Sheet

Overview

The 718-52 is a Mifare reader that is user configurable to read data from a designated sector using a designated key. As this data cannot be copied from the Mifare card it provides a secure card reader.

Card readers are supplied in a factory reset state and are programmed using a configuration card. On power-up all three reader LEDs flash indicating that the reader needs to be configured.

The configuration card is prepared using the Secure Card software and the 719-52 Mifare Card programmer. The configuration card specifies the sector (MAD-AID) and key that contain the application data. It also specifies the reader output format.



A reader can be reconfigured at a future date to have a different sector / key but only if the customer's reconfiguration key is known. This prevents malevolent reconfiguration of the reader.

To ensure security, there is no back-door to reset the reader and if the sector / key are lost the reader can only be reset to the factory default setting by reloading the reader firmware.

User cards may be created using the 719-52 card programming software.

The reader has Wiegand, Mag-stripe and RS232 outputs and supports a number of formats.

The reader can be set to control the LEDs and sounder when a valid/invalid card is read. They can always be externally controlled.

Specifications

- Power requirements: 5.0 to 13.8V dc. Current consumption: 120 mA (typical).
- RF Frequency: 13.56MHz
- Card types supported: mifare® Std 1K and 4K
- Mifare application directory (MAD1 and MAD2) supported.
- Contactless interface as per specification: ISO/IEC 14443 Type A.
- Typical reading range - 20mm to 50mm, dependant upon card manufacturer
- 3 LEDs (GREEN, RED, YELLOW).
- Beeper emits a 4kHz tone
- Operating temperature range: -20°C to +60°C.
- 10 way cable: 1m long
- Weight: 90 grams.
- Dimensions: reader 89 x 45 x 16 mm, optional spacer plate 89 x 45 x 7 mm
- Output formats supported: Wiegand (up to 128 bits), Mag Stripe (up to 20 chars), RS232 (baud rates 2400-57600) EIA and TTL levels.
- The card's UID can be output when in RS232 mode.
- Active Low Inputs for Red LED, Green LED, Yellow LED and Sounder.

Physical Dimensions and Mounting Details

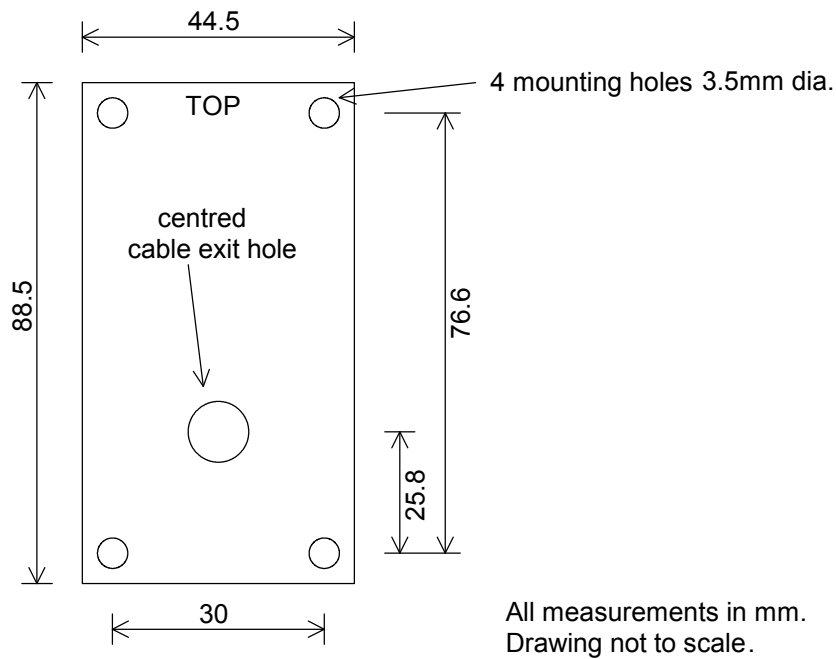

If the spacer plate is used the reader cable may be brought out of one of four exit points on the spacer: top, bottom, left or right. This enables the cable to be run on the surface of the wall. If no spacer plate is used a minimum hole size of 6.5mm must be drilled in the wall at the cable exit position as shown above to allow the cable to exit perpendicular to the reader.

The optional spacer plate may also be used when mounting the reader on a metal surface to reduce the negative effects of metal on the read range.

Connections

The table below details the function of each wire:

Colour	Name	Function
BLACK	0V	Connect 0V to power supply
RED	+VDC	Connect to power supply, +5V to +14V
PURPLE	RS232 TX	RS232 TX ¹
BLUE	BEEP	Connect to 0V to sound beeper
ORANGE	RED LED	Connect to 0V to turn LED on
GREEN	GREEN LED	Connect to 0V to turn LED on
YELLOW	YELLOW LED	Connect to 0V to turn LED on
BROWN	DATA1/DATA	Open collector data output ²
WHITE	DATA0/CLOCK	Open collector data output ²
GREY	RS232 RX	RS232 RX ¹

Note 1. Baud rate is configurable

Note 2. Open collector has a 10k internal pullup to 5V

Normal Operation

Once configured, the reader will read a single block of data stored on a MIFARE card and output this data in a chosen format.

The choice of which sector and block to read, which authentication KEY to use, and which output format to use, is decided by the user. Using the 719-52 Mifare card programmer, a configuration card may be made using the parameters the user has chosen. This card must be presented to the 718-52 reader when it is in the factory reset state. Presenting this card to the reader will load these settings into the reader and the reader is now configured. The Configuration Card may be used on as many readers as required. Following is a full list of configurable reader options:

- Sector Number or Mifare Application ID (when card is configured for MAD).
- Block Number within the sector
- Sector Key (must match Key A in the sector trailer for successful authentication)
- Output format (wiegand, magstripe, RS232)
- Number of bits to read off the card.
- First bit position
- Red LED flash - none, on good read, on failed read, on both.
- Green LED flash - none, on good read, on failed read, on both.
- Beeper sound - none, on good read, on failed read, on both.
- UID output - none, on good read, on failed read, on both. (Only available In RS232 mode.)
- Allow reconfiguration
- Re-configuration key.

Factory Reset State

A new reader will start in the factory reset state and has the following functionality:

LEDS

The red and green LEDS will flash alternatively ON and OFF with a period of 1 second. The LEDS will not respond to any card reading.

Card in Field

The reader will poll a MIFARE card in the field for its UID and if received will attempt to read 'Configuration' data. If the card contains valid configuration data the card's configuration settings will be loaded into the reader which will reset and resume operation in a configured state. Note that all LEDs will be off in the configured state.

Beeper

The beeper will respond with a single 500ms beep if a valid configuration card was read and the settings were accepted.

Configuration Card

Configuration cards can be programmed using the 719-52 Mifare card programmer. A MIFARE Std 1k card is used as a configuration card. The reader uses a factory defined KEY to read the configuration card. To prevent unauthorised re-configuring of readers in the future, the user can do one of two things:

1. Disallow future re-configuration of the reader.
2. Choose a new key to be used for re-configuring the reader.

If you disallow future re-configuration, the reader configuration can only be set back to the factory reset state by reloading the reader firmware.